



Now available with single and three phase motors

ecocirc® XL

A COMPLETE SMART & HIGHLY EFFICIENT PUMPING SOLUTION
FOR HEATING, COOLING AND POTABLE WATER SYSTEMS

Single and three phase models give you exactly what you need in a circulator

The newly expanded ecocirc XL line, with single and three phase motor options, gives you a highly efficient circulator that enhances commercial hydronics systems with superior quality and dependability. State-of-the-art hydraulics, advanced motor design, intelligent controls, and smart communication capabilities highlight expert engineering across a broad range of HVAC and plumbing applications.

Economical operation

A highly efficient ECM motor combined with optimized pump hydraulics, keeps operational costs at a minimum.

Keep it insulated

A perfectly molded insulation shell helps in preserving the constant temperature of the pumped heating medium.

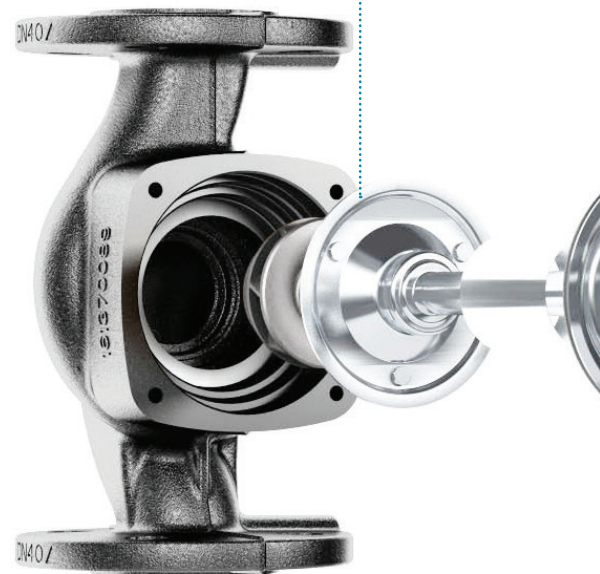
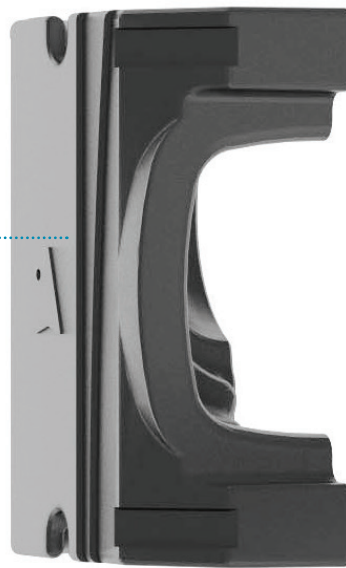

Available with single and three phase motors



The Intelligent Drive essential Controls

The ecocirc XL can operate in 3 different standard control modes:

- Proportional pressure control
- Constant pressure control
- Constant speed

Night mode functionality provides additional energy savings. Advanced settings can be managed from a PC, tablet or smartphone, and are accessible via optional built-in wireless or RS-485 cable.

User-friendly interface

With only four logically placed buttons on an intuitive interface, it's easy to set and operate the new ecocirc XL. Advanced settings enable custom programming, accessible via a PC, smartphone or wireless enabled device.

High visibility

Even in dark mechanical rooms, a bright display with large figures and symbols makes it easy to view pump status.

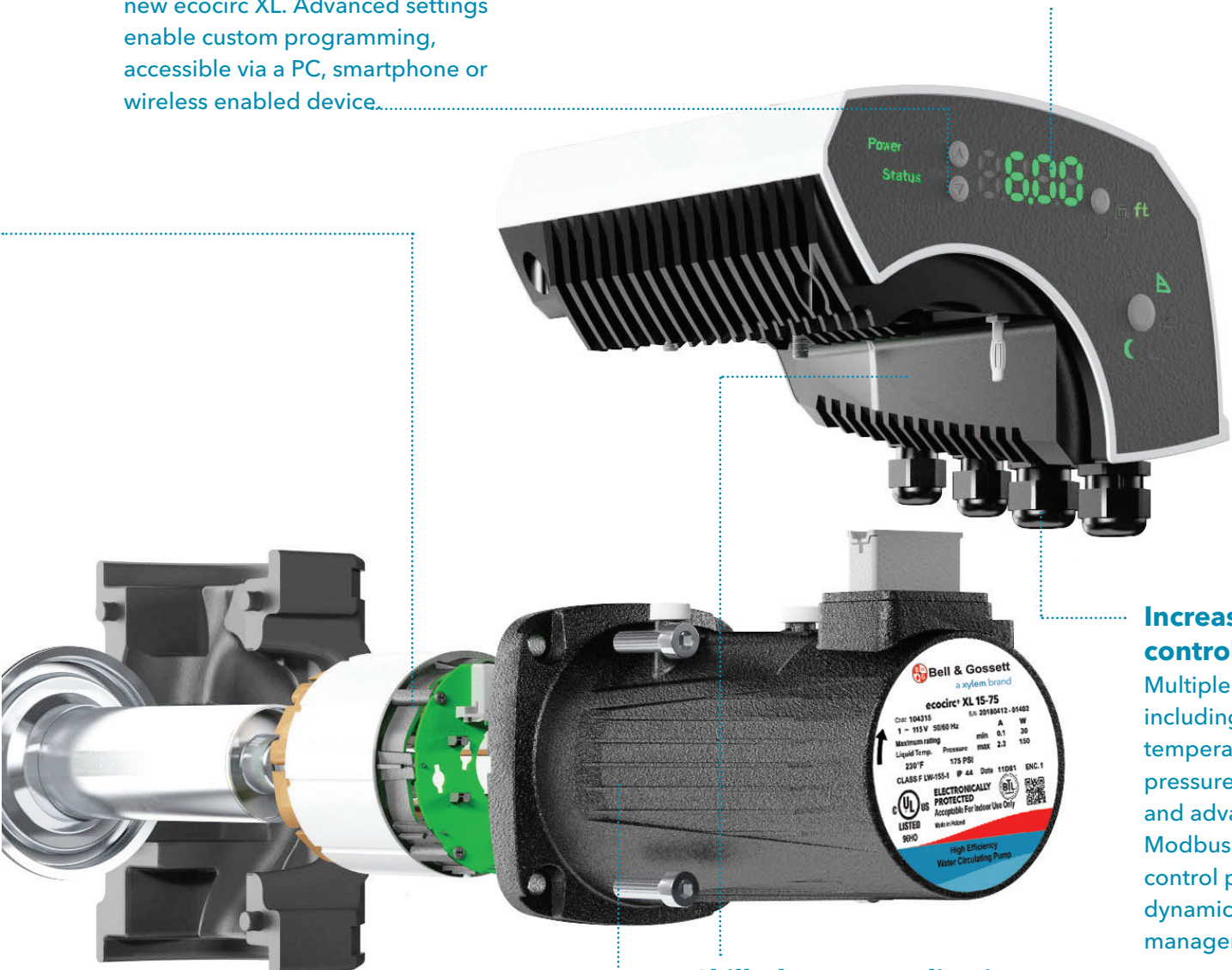

Increase your control options

Multiple inputs including start-stop, temperature control, pressure regulation and advanced Modbus or BACnet control provide dynamic system management.

Pump protection

Built-in dry-run protection stops pump operation in the absence of water, preventing damage and costly repairs.

Chilled water applications

Electronics are separated from the pump to prevent condensation for worry free operation even at 14°F (-10°C).

evolved Communication

- The ecocirc XL communicates with advanced Building Management Systems via Modbus or BACnet protocols.
- Two analog inputs - one for the differential pressure sensor (4-20 mA), and another (0-10V) for speed control
- An external temperature probe can be added for more advanced temperature control.
- Start-stop functionality is built-in.
- Built-in parallel pump communication.

enhanced Monitoring

- If something unexpected occurs, alarm and error codes are displayed and stored in a data log.
- Runtime data is stored for optimized settings.
- Simplifies problem diagnostics.

Easy selection from a large performance coverage with as few models as possible

Performance targeted to individual specifications is delivered across a broad spectrum of head and flow requirements. The simple pump model description makes the selection process easier to find the correct unit for any application.

ecocirc XL High Head Performance Range

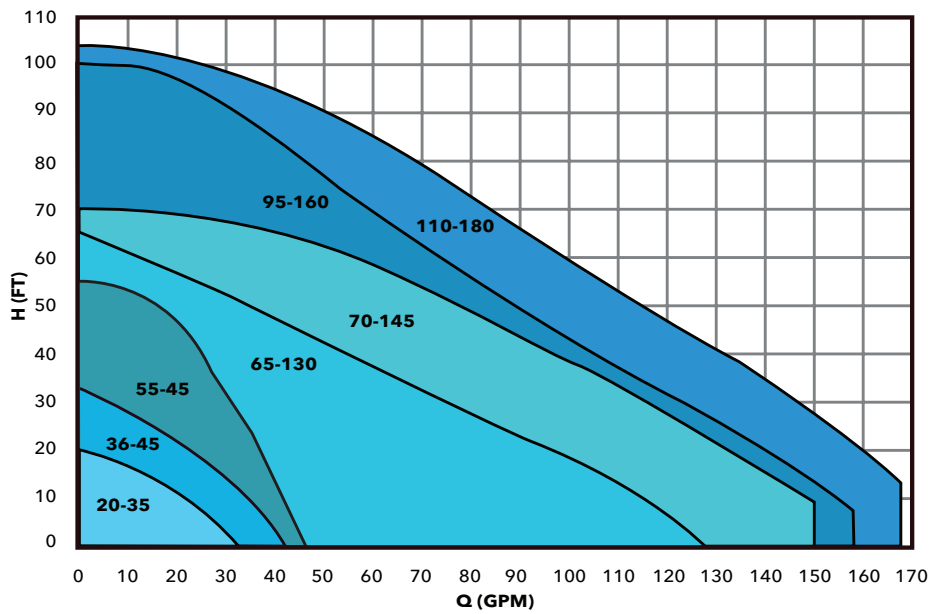

ecocirc XL High Flow Performance Range

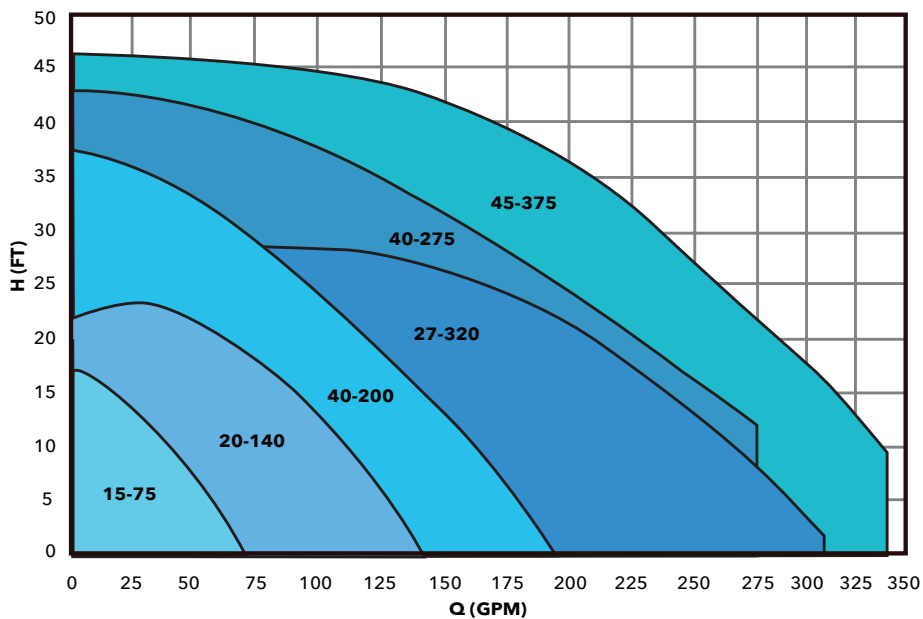

Communicates Clearly

A simplified, user-friendly status display keeps the installer informed on pump settings and performance. Communicate with Modbus and BACnet systems, or use wireless connectivity to communicate with the pump for remote control from your smart phone or wireless enabled device.



Features
Control Modes
Proportional Pressure curve ($\Delta p-v$)
Constant Pressure curve ($\Delta p-c$)
Constant Speed curve
Automatic Night mode
Temperature Control Modes
T-Constant Control
ΔT -Constant Control
$\Delta p-T$ (Paired with proportional or constant pressure mode)
Readings and settings on the pump
Control and display panel
Operating status
Warning and alarm
Errors and work log history
Dry running detection
Input/Output
2 x analog inputs (0-10V / 4-20mA)
1 x external temperature sensor input
1 x start/stop input
1 x status output
2 x absolute pressure sensors (3 phase only)
Communication and monitoring
Built-in parallel pump communication
Communication with Modbus or BACnet standard BTL certified
Communication with PC/Laptop
Wireless module for short range wireless communication (optional)

With 15 models to choose from there's always an exact match for any system.

The ecocirc XL is a high efficiency, variable speed, wet rotor pump with integrated drive. The circulator is available in cast iron or stainless steel and with a broad temperature range of 14°F to 230°F (-10°C to 110°C). The ecocirc XL is suitable for both hot and chilled water systems. Three phase motors are now available.

Product Range Chart

Model Number	Version		Power Supply				Flange Connection				Pump Body		Fluid Temp. Range	Ambient Temp. Range	Maximum Pressure Range	Protection Class
	High Head	High Flow	Single Phase 115V	Single Phase 208-230V	3 Phase 208-230/400-460V	3 Phase 400-460V	Small Booster (2 Bolts)	Large Booster (2 Bolts)	2" Booster (4 Bolts)	3" Booster (4 Bolts)	Cast Iron	Stainless Steel	14°F - 230°F	32°F - 104°F	175 PSI	IP44
ecocirc XL 20-35	•		•				•				•	•	•	•	•	•
ecocirc XL 36-45	•		•	•			•				•	•	•	•	•	•
ecocirc XL 15-75		•	•	•					•		•	•	•	•	•	•
ecocirc XL 55-45	•			•			•				•	•	•	•	•	•
ecocirc XL 20-140		•		•					•		•	•	•	•	•	•
ecocirc XL 65-130	•			•				•			•	•	•	•	•	•
ecocirc XL 40-200		•		•					•		•	•	•	•	•	•
ecocirc XL 70-145	•			•				•			•	•	•	•	•	•
ecocirc XL 40-275		•		•							•	•	•	•	•	•
ecocirc XL 65-130	•				•			•			•	•	•	•	•	•
ecocirc XL 40-200		•			•				•		•	•	•	•	•	•
ecocirc XL 95-160	•				•			•			•	•	•	•	•	•
ecocirc XL 27-320		•			•						•	•	•	•	•	•
ecocirc XL 110-180	•					•		•			•	•	•	•	•	•
ecocirc XL 45-375		•				•					•	•	•	•	•	•

*304 stainless steel body - certified to NSF 372.

- Small Booster (2 bolts) has a bolt hole to bolt hole dimension of 3-3/16".
- Large Booster (2 bolts) has a bolt hole to bolt hole dimension of 3-7/16".

Product nomenclature



Service and support from the most trusted name in the industry - Bell & Gossett.

The Bell & Gossett name has always stood for uncompromising quality and dependability. That's evident in the way every one of our centrifugal pumps is built and backed by our outstanding customer service and support team.

Your local Bell & Gossett representative is available any time and is an experienced professional with a wealth of technical expertise. In addition to expert system and product application assistance and a wide product inventory warehoused locally, we offer ESP-Systemwise software selection program.



ESP-Systemwise is a Bell & Gossett web-based software that helps you design HVAC systems accurately, effectively and very quickly. You get fast, precise equipment selection, pump performance curves and equipment schedules, submittals, specifications and more.

ESP-Systemwise includes:

- Centrifugal Pumps
- Air/Dirt Separators
- Drives and Controls
- Expansion Tanks
- Heat Exchangers
- PIC Valves
- Replacement Parts
- Suction Diffuser and Triple Duty Valve
- Wastewater/Stormwater

The Little Red Schoolhouse® - Training the Industry



Seminars currently offered are:

- Modern Hydronic System Design - Basic*
- Modern Hydronic System Design - Advanced*
- Design & Application of Water Based HVAC Systems
- Large Chilled Water System Design*
- Pump Service & Maintenance School
- Steam Systems Design & Applications
- Steam System Operation & Maintenance
- Plumbing Systems Design

Bell & Gossett has long been known for its dedication to training. The "Little Red Schoolhouse®" has graduated over 60,000 students since it was founded in 1954.

Graduates from the "Little Red Schoolhouse" may be found throughout North America, Europe, Africa, Asia and Australia.

For applications to attend these seminars, please contact a Bell & Gossett Representative in your area. They will have the schedule dates for all seminars and will make all the arrangements for you. As a service and a continuing educational source to the HVAC industry, these seminars are offered free of charge. IACET certified CEU credits are awarded for each seminar.

* The USGBC has approved the technical and instructional quality of the Modern Hydronic Heating Systems - Basic Seminar (15 GBCI CE Hours) and the Large Chilled Water Design Seminar (11 GBCI CE Hours). These courses are approved for GBCI Continuing Education Hours towards LEED Credential Maintenance Programs.



Xylem |'zīləm|

- 1) The tissue in plants that brings water upward from the roots;
- 2) a leading global water technology company.

We're a global team unified in a common purpose: creating advanced technology solutions to the world's water challenges. Developing new technologies that will improve the way water is used, conserved, and re-used in the future is central to our work. Our products and services move, treat, analyze, monitor and return water to the environment, in public utility, industrial, residential and commercial building services settings. Xylem also provides a leading portfolio of smart metering, network technologies and advanced analytics solutions for water, electric and gas utilities. In more than 150 countries, we have strong, long-standing relationships with customers who know us for our powerful combination of leading product brands and applications expertise with a strong focus on developing comprehensive, sustainable solutions.

For more information on how Xylem can help you, go to www.xylem.com

We value your feedback. Please take our 3 question survey at **bellgossett.com/survey** to let us know how we are doing.



Xylem Inc.
8200 N. Austin Avenue
Morton Grove, Illinois 60053
Phone: (847) 966-3700
Fax: (847) 965-8379
www.xylem.com/bellgossett

Bell & Gossett is a trademark of Xylem Inc. or one of its subsidiaries.
© 2018 Xylem Inc. A-162D December 2018